

# M10Pro Micro Turbojet Engine

## Quick Start Guide

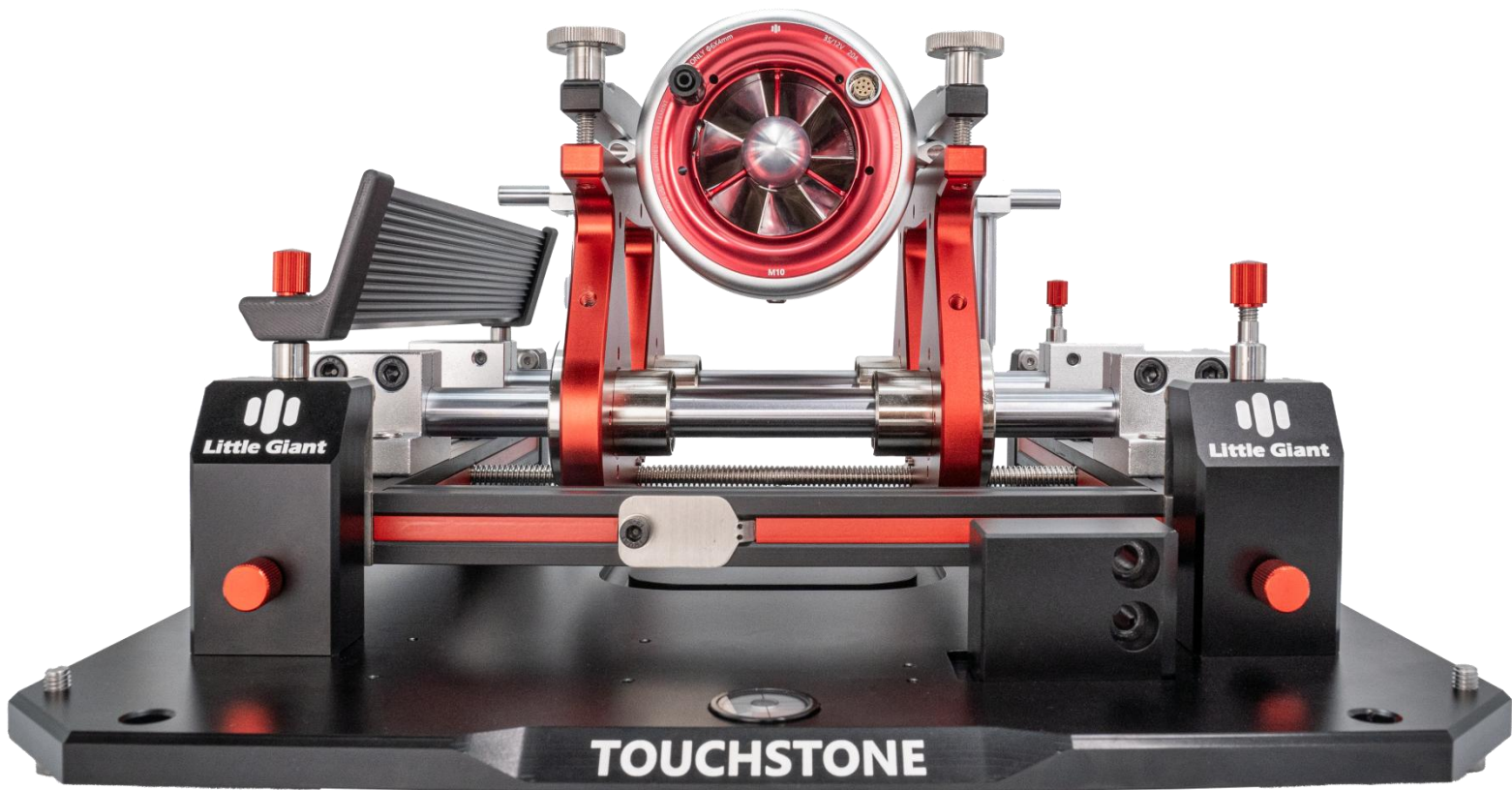

Little Giant

2026.03.09

This guide applies to: ECU-M10P-V1.28 and above

## Table of Contents

1. Introduction .....	1
(1) Unique product features .....	1
(2) UniqueProduct Specifications .....	2
(3) Product dimensions .....	2
(4) What is supplied with our engine .....	3
2. Safety Information .....	4
(1) Keeping a safe distance .....	4
(2) Fire Handling Procedures .....	4
3. Engine Connection and Installation .....	4
(1) Engine Connection .....	4
(2) Electrical Connection .....	8
(3) Engine Installation .....	12
4. Operating Instructions .....	15
(1) Pre-Start Checks .....	15
(2) Throttle Learning .....	17
(3) Fuel Pump Operation .....	18
(4) Maximum Thrust Setting .....	20
(5) Engine Start .....	20
(6) Adaptive Learning .....	23
(7) Acceleration and Deceleration Settings .....	24
(8) Stall Restart .....	25
(9) Loss of Control Protection Strategy .....	25
(10) Engine Shut-down .....	26
(11) Manual Cooling .....	26
(12) Viewing Historical Data .....	27
(13) Advanced Settings .....	28
(14) Fault Information and Solutions .....	32
5. Definitions of Terms .....	36
6. Disclaimer .....	37
7. Warranty Policy .....	38

---

# 1. Introduction

## (1) Unique product features

Thank you for choosing the Ftl Vortex (Little Giant) M10 Pro turbine this engine is equipped with the following features.

A. This engine is equipped with variable thrust from 6-10kg allowing its use to be customised to your requirements. It is also significantly smaller than other models of the same thrust value.

B. Among engines of this thrust class, the M10Pro is the world's first engine with a built-in electric starter motor. While ensuring the engine's intake airflow and improving various engine performance indicators, it also significantly reduces start-up failures caused by structural shortcomings of traditional starting systems.

C. Among engines of this thrust class, the M10Pro is the world's first engine with all accessories fully integrated internally (fuel pump, solenoid valve, ECU, various sensors), fully considering user convenience.

D. This engine is the first to feature a fuel bubble detection function. It consists of an optical detection sensor integrated at the fuel inlet and a post-processing circuit, which can detect air bubbles in the fuel line, display them, record them, and remotely notify the user. This helps users clearly identify any air leakage in the fuel system.



## (2) Unique Product Specifications

M10Pro Turbojet Engine Specifications							
No.	Item	Unit	Value	No.	Item	Unit	Value
1	Standard Idle Speed	RPM	46,000	13	Flight Weight	g	997
2	Maximum Speed	RPM	150,000	14	Diameter	mm	91
3	Idle Thrust	N	5	15	Length	mm	176
4	Maximum Thrust	N	105	16	Battery Type	—	LI-PO3S
5	Exhaust Gas Temperature (EGT)	°C	695	17	Fuel Type	—	Jet Fuel / Automotive Diesel
6	Compression Ratio	—	3.7	18	Lubricating Oil	—	Mobil Super 2T 5% Mix Ratio
7	Air Flow Rate	kg/s	0.242	19	ECU (Engine Control Unit)	—	Built-in
8	Maximum Exhaust Velocity	m/s	430	20	Fuel Pump	—	Built-in
9	Maximum Power	kw	7.9	21	Starter Motor	—	Built-in
10	Idle Fuel Consumption	ml/min	80	22	Power Generation	—	Built-in
11	Maximum Fuel Consumption	ml/min	380	23	Maintenance Interval	h	2.5
12	SFC (Specific Fuel Consumption)	kg/ (kgf·h)	1.85	24	Air Conditions: 1 atm, 15°C; Jet Fuel Density: 0.812 kg/L		

## (3) Product dimensions

单位: mm

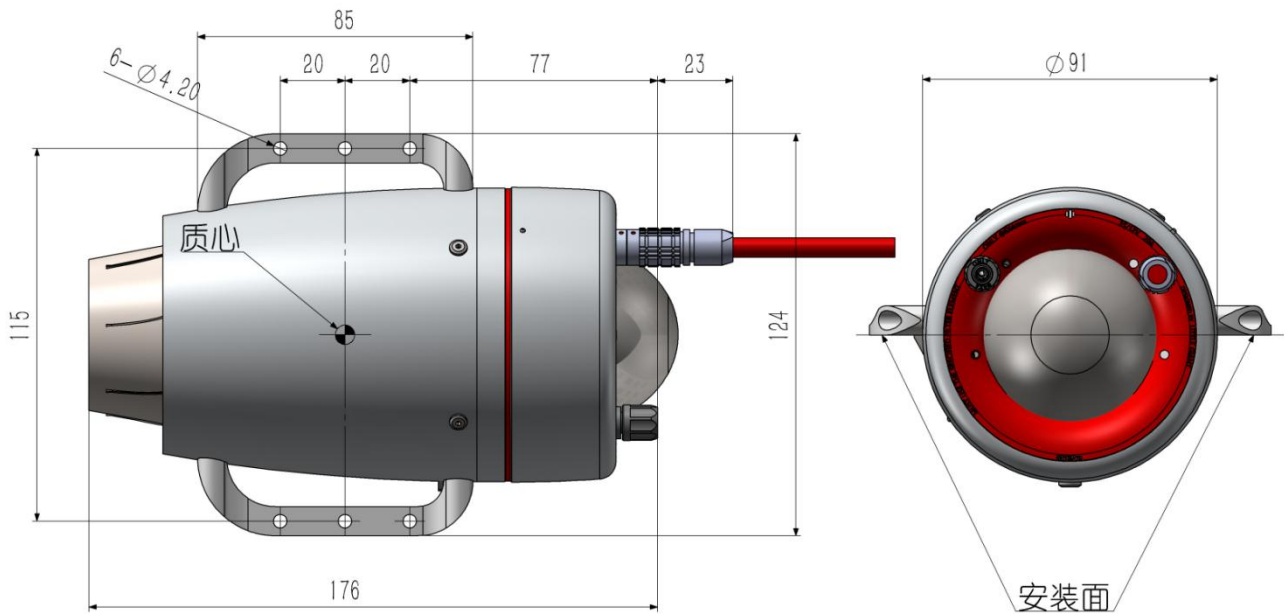

单位: mm

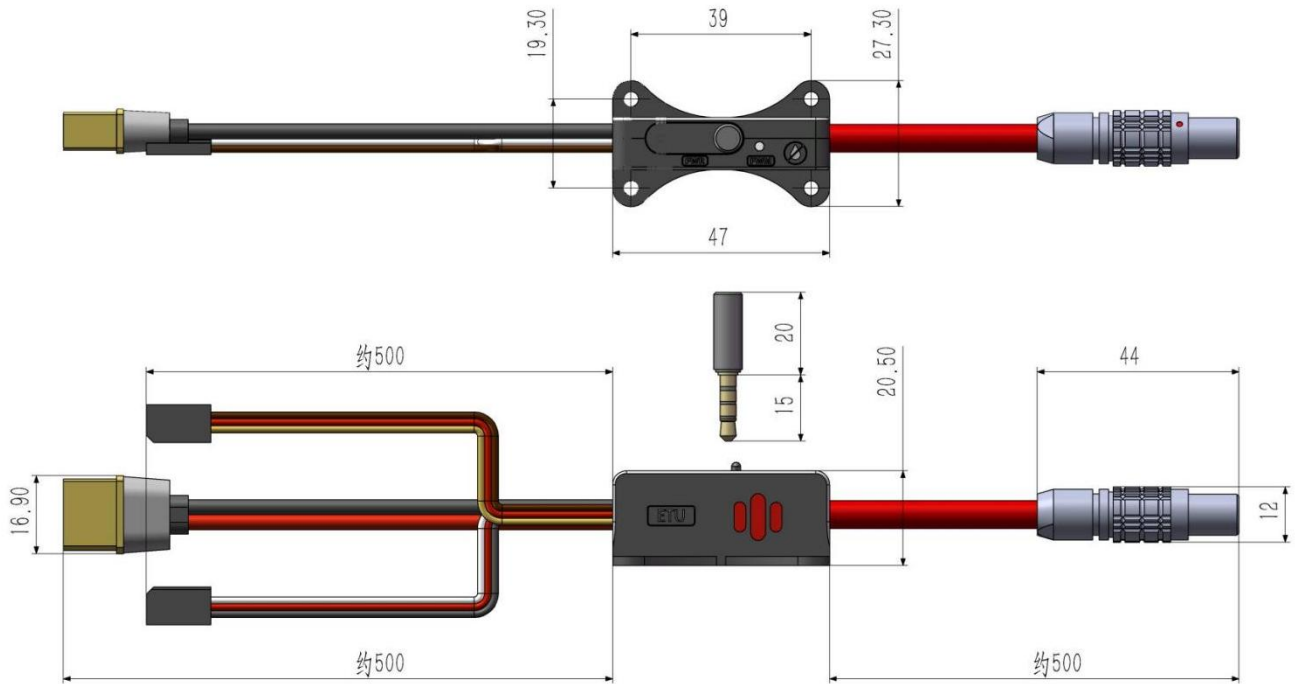

#### (4)What is supplied with our engine

◆items may change over time when there is an update .



---

## **2. Safety Information**

### **(1) Keeping a safe distance**

A. When the engine is running, please keep a safe distance: at least 3 meters in front of the engine (air intake side), at least 5 meters on both sides, and do not approach the rear of the engine (jet exhaust side).

B. The engine can only be started outdoors. Before starting, prepare a CO<sub>2</sub> fire extinguisher of at least 2 kg.

C. If the engine fails to start multiple times or if the fuel tank pressure is too high, a large flame may be ejected during start up. In this case, immediately set the remote control trim to "Shut down" (or disconnect the power battery), and promptly close the fuel line ball valve. After the flame disappears, reconnect the battery so the engine can automatically cool down. Once the automatic cooling is complete, the engine may be started again.

### **(2) Fire Handling Procedures**

If a fire occurs due to an on board aircraft battery, or engine malfunction, the flames can quickly spread between the battery, engine, and fuselage. When such a situation occurs on the ground, the handling method is as follows:

On-site personnel must remain calm and avoid panic. Immediately evacuate unrelated people nearby, ensuring personal safety first.

While ensuring your own safety, immediately cut off the power supply, close the fuel line ball valve, and use a CO<sub>2</sub> fire extinguisher at close range to extinguish the burning area. At the same time, pay attention to cooling and protecting the fuel tank and engine to prevent the fire from spreading to these parts. If the aircraft structure remains intact, aim the nozzle of the CO<sub>2</sub> extinguisher at the aircraft's air intake. Press the handle intermittently every 0.5 seconds to pulse-inject CO<sub>2</sub> into the aircraft interior.

If there is spilled fuel on the ground, first try to tow the aircraft away from the danger zone, then extinguish both the aircraft and ground flames.

## **3. Engine Connection and Installation**

### **(1) Engine Connection**

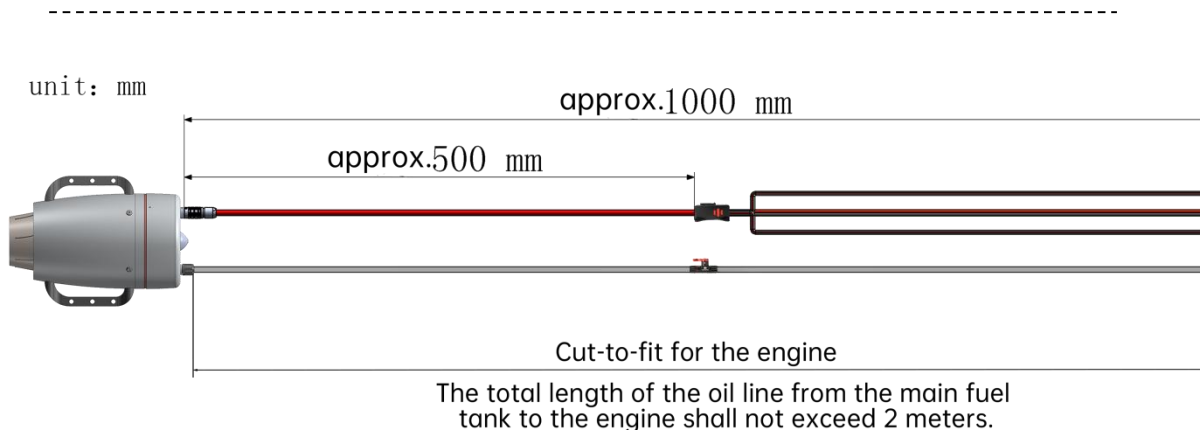

The M10Pro engine is very easy to connect. It only requires one main harness and one fuel line to operate. The main harness, fuel line, fuel filter, mounting bracket, and other accessories are included in the engine packaging.

### M10Pro Electrical and Fuel Connection Diagram

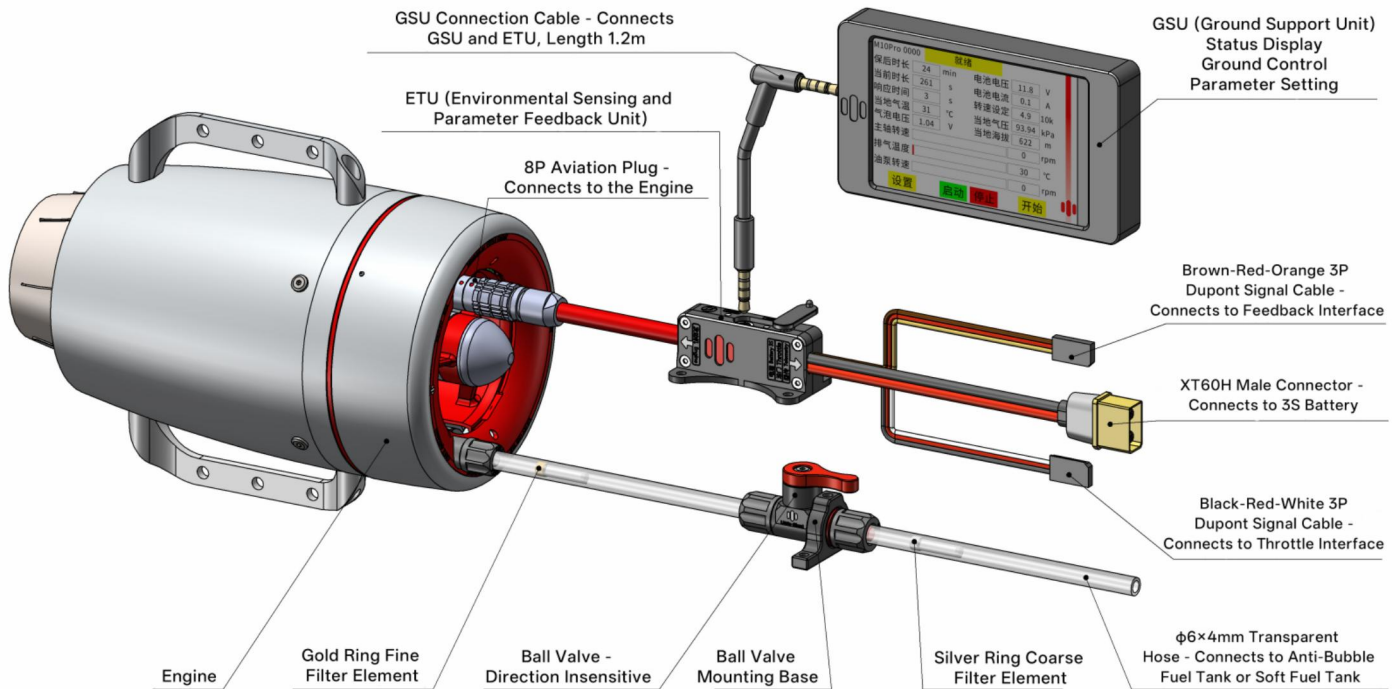

## A. Fuel Line Connection

a. For the fuel line connection, please use a transparent PU fuel hose with an outer diameter of 6 mm and an inner diameter of 4 mm. A 1.5-meter clear PU tube is included for fuel delivery, with the fuel filter already installed inside the PU tube. The fuel flow sequence is: **Fuel Tank** → **Coarse Fuel Filter** → **Ball Valve** → **Fine Fuel Filter** → **Engine**. The total fuel line length must not exceed 2 meters. For filter element disassembly and reassembly, please refer to the video “Method for Disassembling and Assembling the In-line Fuel Filter.”

b. After the hose is locked onto the interfaces of the ball valve and engine, the tensile strength

---

depends on the thickness and hardness of the hose itself. When users use their own hoses, the wall thickness tolerance must not exceed  $\pm 0.05\text{mm}$ , otherwise the designed locking force cannot be achieved, or the locking cap cannot be installed properly.

The fine fuel filter is a golden circular ring, installed 15 mm in front of the tightening joint at the fuel inlet. The mesh end of the filter element should face the incoming flow direction to allow visual monitoring of filter clogging status.

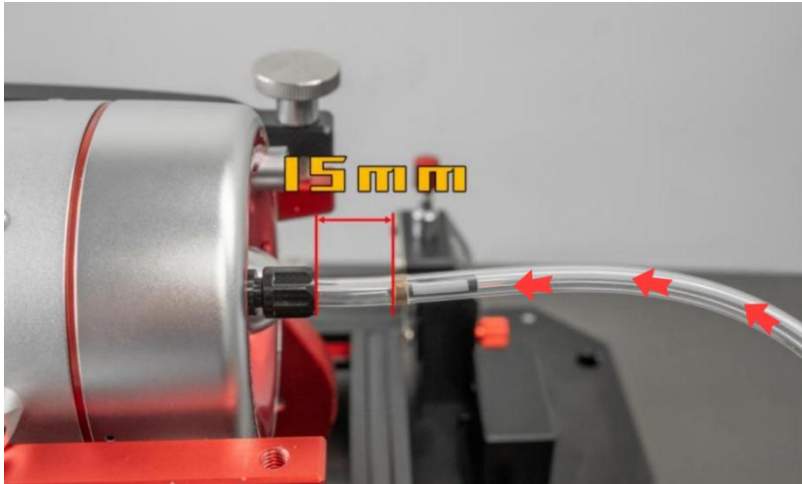

The coarse fuel filter is a silver circular ring, installed 15 mm in front of the ball valve. The mesh end of the filter element should face the incoming flow direction to allow visual monitoring of filter clogging status.



c. The dual fuel filters not only extend the service life of the filters but also improve filtration accuracy.

d. Due to the built-in fuel pump, this fuel line is a negative pressure transmission system. In this system, you must use the locking-joint ball valve provided in the package. Do not use quick-connect ball valves, as this ensures the airtightness of the fuel line connections and effectively prevents engine stalling.

-----

e. Following the same principle, if the hose end shows obvious signs of loosening, or if it has been in use for more than 4 months, cut off 10 mm from the end of the hose and reinstall it. This ensures the airtightness of the fuel line connections and effectively prevents engine stalling.

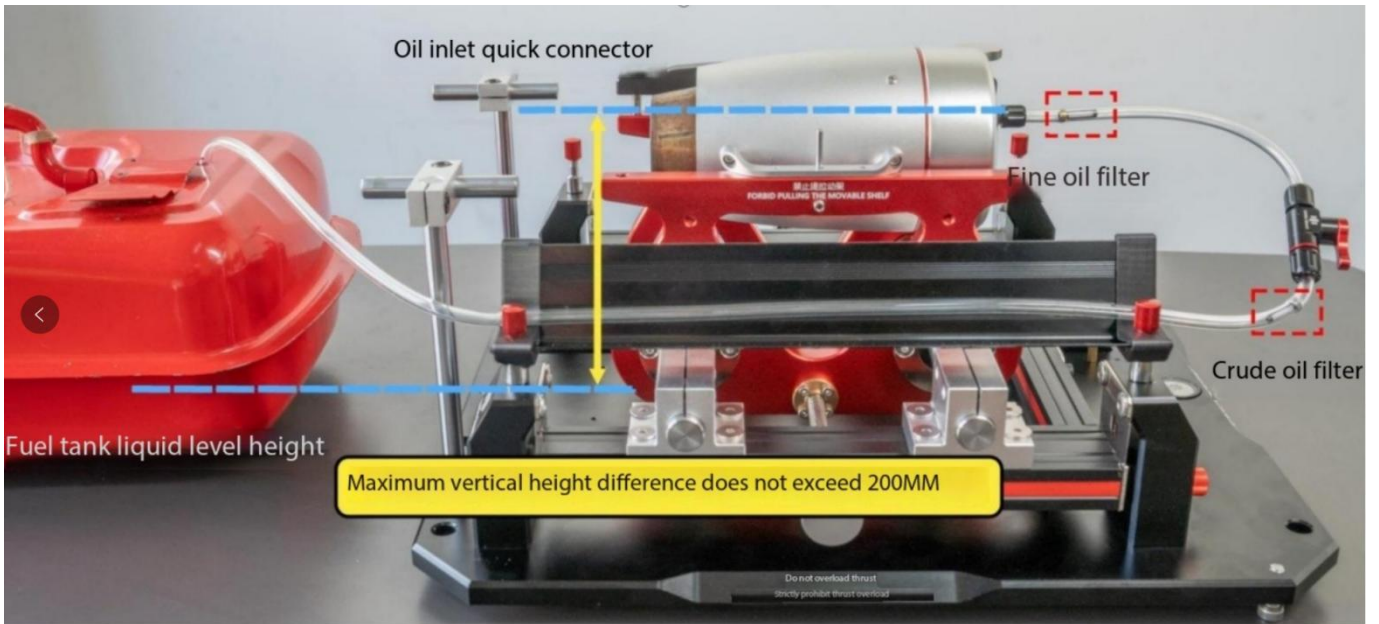

f. When using a soft fuel tank, as mentioned earlier, the ball valve must remain closed during refuelling. After completing the pressurization and venting process, some fuel should be drawn back into the fuel can to keep the soft fuel tank as relaxed as possible. If the ball valve is opened more than 5 seconds after ignition, the engine may fail to detect fuel, causing the startup to terminate and resulting in a failed start.

g. To confirm the reliability of the fuel line connection: after starting the engine, run it at high throttle and check whether bubbles are present in the fuel line. Bubbles are the main cause of engine stalling and must be carefully monitored. On the M10Pro model, the bubble status can be viewed on the main interface at the upper right corner. If bubbles appear in the fuel line during operation, their values will be displayed numerically in this location. After shut-down, long-press the “Stop” button for 2 seconds to clear the displayed value.

h. The maintenance cycle of the filter element varies greatly depending on the impurity content of the fuel. Generally, when impurities visibly cover more than 50% of the filter mesh surface, the filter element must be serviced. It is recommended to use the included special disassembly tool to directly replace the filter element, though back flushing may also be performed.

i. For back flushing the fuel filter, remove the filter together with the connected pipelines at both ends. Use a new syringe of at least 20 ml, draw clean fuel, and connect the syringe (without a needle) to the filter in the reverse direction of fuel flow. Forcefully push the syringe plunger so that the 20 ml is expelled in about 2 seconds. Repeat this back flushing process at least 5 times, then flush in the normal flow direction twice. This can roughly restore the filter element’s performance.



j. The use of wool felt, metal sintered, or non-fuel-specific filter elements is strictly prohibited, as they may cause severe damage to the engine.

k. Users in cold regions using diesel fuel should be aware of wax formation in diesel at low temperatures (below 4°C), which can easily clog the fuel filter and fuel pump. This can cause issues such as failure to start, inability to reach maximum RPM, fuel line blockage warnings, and sudden engine shut-down. These problems can be resolved by switching to kerosene as the fuel.

## (2)Electrical Connection

### A. Aviation Connector Connection

Connect the aviation plug male and female connectors by aligning the red dots. The aviation connectors have sealing and locking structures. When removing, do **not** pull the cable directly; you must pinch the unlocking sliding ring before pulling out the connector.

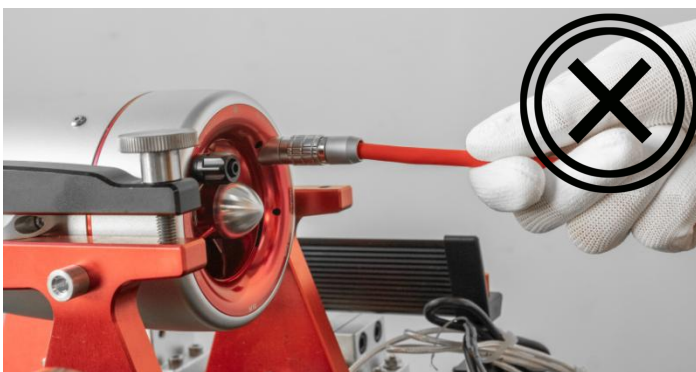

---

◆ When the engine is not in use, promptly install dust caps on the aviation connectors and fuel line quick couplings ◆

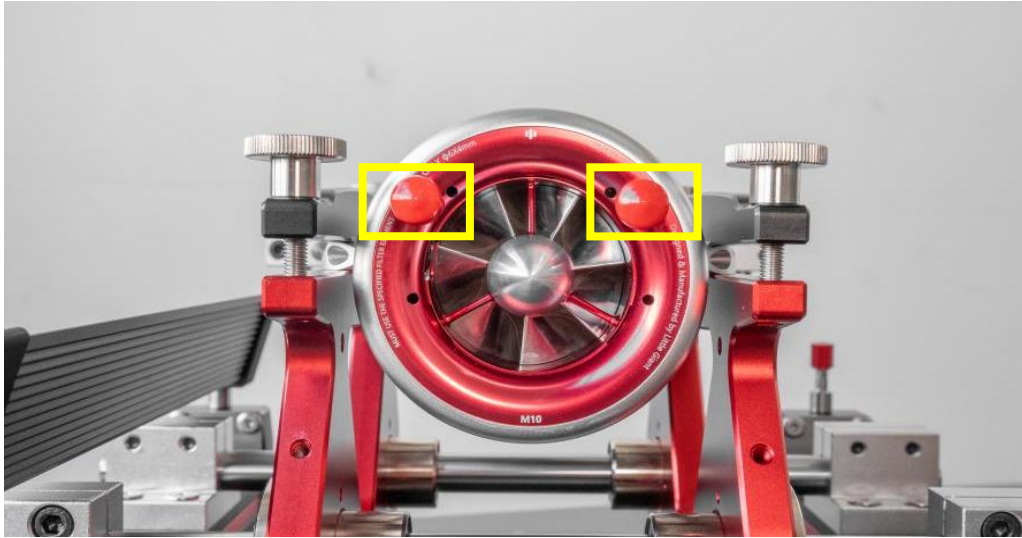

## B. Power Connection

Only supports the use of 3S LiPo batteries, capacity  $\geq 2200\text{mAh}$  (3300mAh recommended), voltage range: 11.4–12.6V. Use an XT60H connector for connection, with the engine side using the male connector.

A DC 12V 20A regulated power supply can also be used.

After connecting the XT60H external power supply and plugging the aviation connector into the engine, the small power indicator light on the ETU (Environment Sensing and Parameter Feedback Unit) will turn on, as shown in the figure below. This indicates that the logic part of the engine control unit is powered normally.

## C. Throttle Signal Wire Connection

Insert the throttle signal wire (black, red, white) into the receiver's throttle channel in the correct orientation. After the receiver is connected and powered (some receivers require pairing with the remote controller first), the throttle signal indicator light on the ETU will turn on, as shown in the figure below.

The throttle signal light will only turn on when the engine control unit recognizes a correct PWM signal. If the wire is inserted incorrectly or the signal is abnormal, the light will not turn on.

Therefore, the status of this light can be used as a basis for determining whether the throttle signal wire is correctly connected.

Note: The throttle signal wire does not supply power to the receiver. The receiver must be powered externally, with the voltage range depending on the receiver.



**Engine power indicator**

**Throttle signal indicator**

## **D. Feedback Signal Wire Connection**

Insert the feedback signal wire (brown, red, orange) into the feedback port of the receiver.

## **E. UAV UART Communication**

The M10 series engine supports UAV UART communication and can connect to the UAV flight controller. Via a preset protocol, the flight controller can control operations such as engine start/stop and speed adjustment, while acquiring all real-time operating parameters of the engine. The UART communication cable comprises RX (Receive) Line, and other components. Users may self-manufacture the communication connector according to the following wiring diagram, or contact Xiaojuren Company to purchase high-quality dedicated connectors and cables for flight controller connection.



## M10Pro UART Communication Wiring Diagram

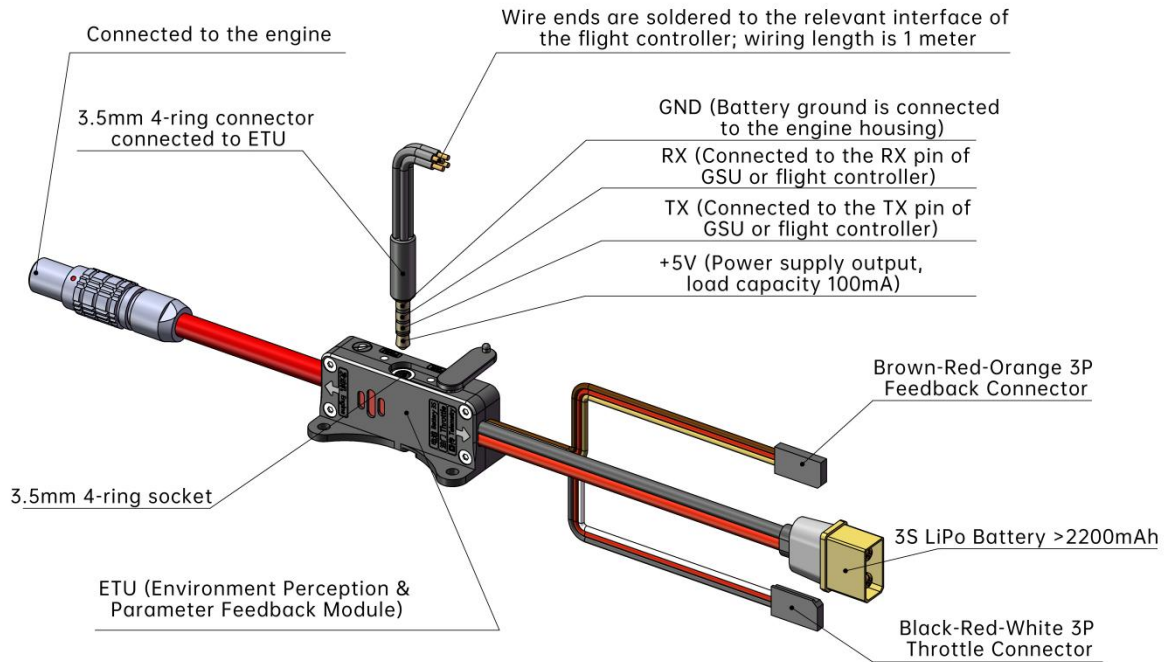

### F. ETU Overview

The ETU (Environment Sensing and Parameter Feedback Unit) is used to detect ambient atmospheric pressure and temperature. These parameters are displayed on the main interface of the GSU. This function enables the engine to respond to changes in the atmospheric environment by automatically adjusting relevant operating parameters during startup and operation, thereby adapting to the atmospheric conditions of different regions or seasons and ensuring the engine starts and operates normally. Factory personnel can also use the prompts from these parameters to assist users in manually adjusting and attempting to start engines that fail to start properly. The ETU housing is made of aluminum alloy. To ensure the sensor chip can sensitively detect atmospheric environmental information, a window shaped like the "Little Giant" logo is opened on the aluminum alloy housing to connect the sensor chip with the external atmosphere. A waterproof and breathable membrane is attached to the back of the window to prevent external liquids (such as fuel) and foreign objects from entering the module. Do not pierce this membrane with sharp objects. The waterproof and breathable membrane is available in two specifications: red and black. Note that neither the engine nor the module is waterproof. Using the engine in rainy weather or allowing water to enter will cause severe damage to the engine.



The M10 series engines integrate the parameter feedback unit directly into the engine wiring harness for the first time, so users do not need to purchase it separately. This unit consists of a microprocessor and a data exchange chip, which transmit real-time engine operating parameters back to the remote controller. Depending on the remote controller's functionality, parameters such as engine RPM, fuel consumption, engine temperature, battery current, and battery voltage can be fed back.

Currently, the engine supports telemetry with **JETI, FrSky, and Futaba** remote controllers, with support for up to **two engines transmitting simultaneously**.

For users requiring the telemetry function, please refer to the corresponding remote controller's *Telemetry User Guide*, available in both video and text formats.

### (3)Engine Installation

#### A. Relative Installation Position of the Ejector Nozzle

A proper nozzle installation position can maximize engine thrust. It is recommended to select and install the ejector nozzle according to the dimensions shown in the figure below. For ejector nozzles with a bowl-shaped inlet, adjust the distance between the rear edge of the engine housing and the inlet end face of the ejector nozzle to 10-20mm. For ejector nozzles without a bowl-shaped inlet, the distance between the engine nozzle outlet and the throat inlet of the ejector nozzle should be 30-40mm.

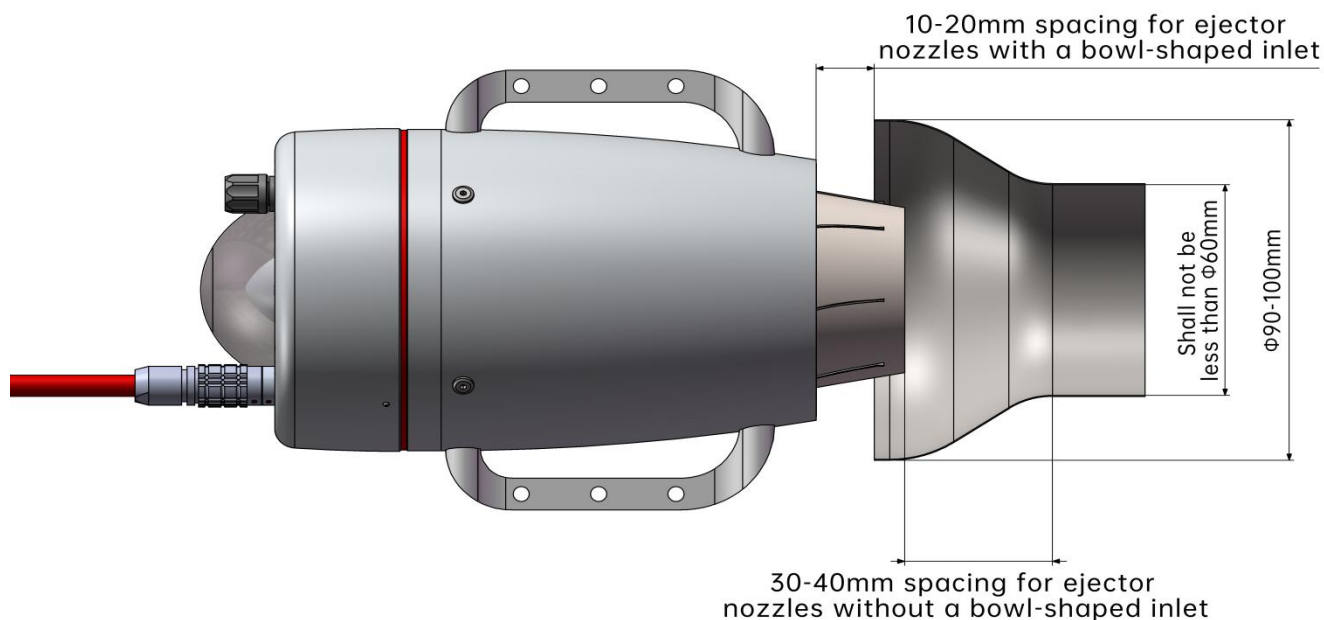

---

## B. Engine Centre of Gravity Position

The mounting holes in the middle of the mounting plates on both the left and right sides of the engine: the midpoint of the connecting line between the centers of these holes is the center of mass of the engine. This position can be used as a preliminary balancing reference when designing the aircraft and installing the engine.

单位：mm

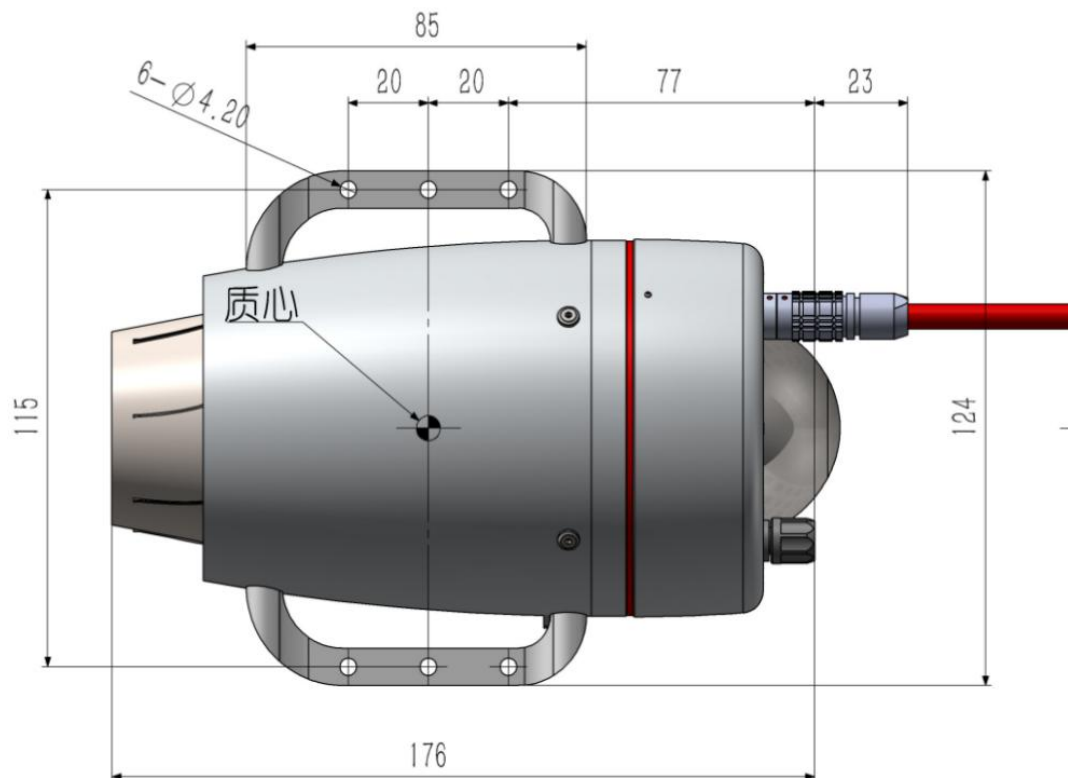

## C. Mounting Plate Temperature

During engine operation, the nozzle temperature is relatively high. Heat from the nozzle will conduct to the rear end of the mounting plate. When installing the engine, the rear end of the mounting plate must not come into contact with plastic materials. Balsa wood can contact the mounting plate and be used normally.

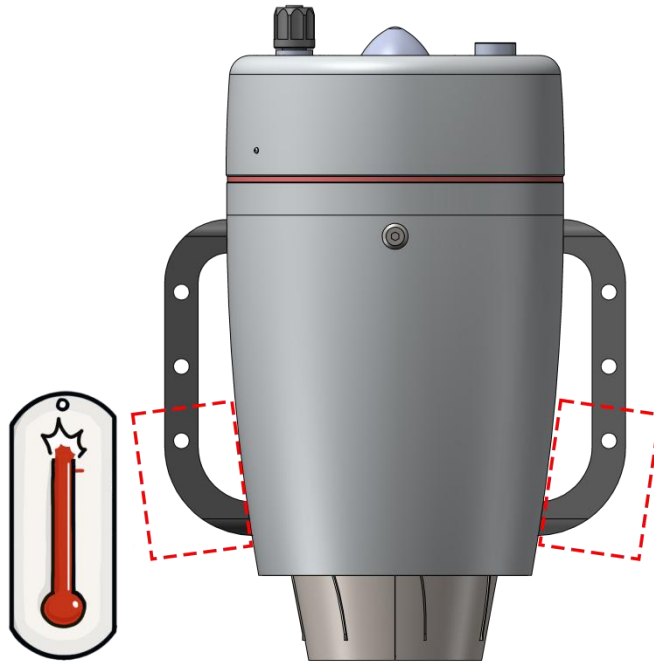

#### **D. Multiple Engine Installation**

When installing multiple engines simultaneously, electrical insulation shall be maintained between the metal housings of all engines to ensure no electrical continuity between them. Otherwise, the ECU power drive section may burn out.

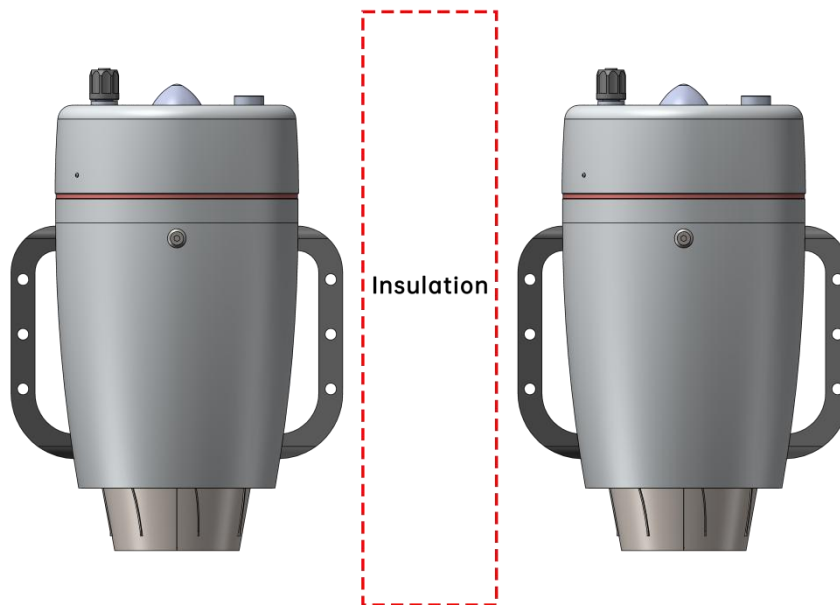

---

# 4. Operating Instructions

## (1) Pre-Start Checks

### A. Power-On Self-Test

After the engine is powered on, it will automatically perform a self-test under certain conditions. When the self-test is complete, the engine's starter motor will emit three short beeps ("di-di-di"), indicating the self-test has finished successfully and no faults were detected. The GSU will then display the main interface.

◆ During the power-on self-test process, do not insert or remove the GSU to avoid inaccurate self-test.

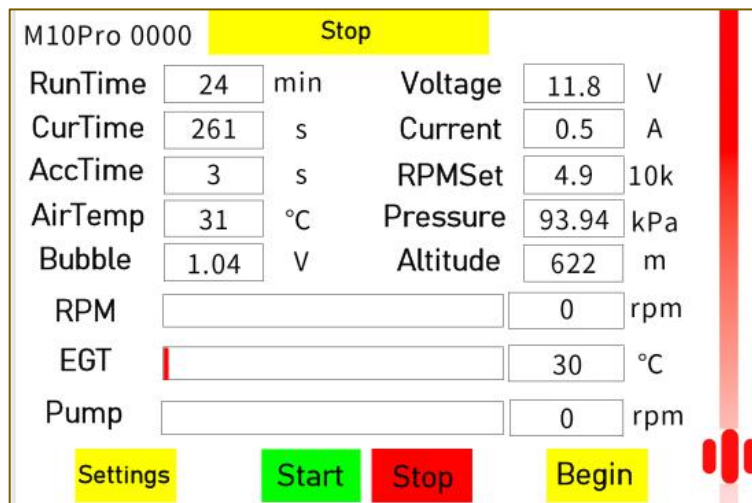

---

## B. Manual Component Inspection

a. When the self-check is completed, if the engine starter motor emits a continuous, uninterrupted alarm sound, it indicates that the self-check is complete and a fault is present. The GSU will display the main page, and the fault type will be shown in the upper right corner of the screen.

The screenshot shows the main page of the GSU. At the top left, it displays 'M10Pro 0000'. The status is 'Stop' in a yellow box, and a fault 'FireValveBad' is shown in a yellow box at the top right. The page is divided into two columns of data:

RunTime	24	min	Voltage	11.8	V
CurTime	261	s	Current	0.5	A
AccTime	3	s	RPMSet	4.9	10k
AirTemp	31	°C	Pressure	93.94	kPa
Bubble	1.04	V	Altitude	622	m
RPM				0	rpm
EGT				30	°C
Pump				0	rpm

At the bottom, there are four buttons: 'Setup' (yellow), 'Start' (green), 'Stop' (red), and 'Begin' (yellow). On the right side, there is a vertical red bar with three red circles at the bottom.

b. At this time, pressing the “Stop” button will clear the alarm.

c. Through the GSU, enter the “Settings” menu to manually test each engine function. If it is determined that the issue is a false alarm from the self-check, you can start the engine following the normal procedure.

d. If the fault cannot be resolved, please contact after-sales technical support.

The screenshot shows the 'Manual Test' menu. On the left side, there are three sections:

- Temp Unit:** A green button for '°C' and a grey button for '°F'.
- Restart Set:** A green button for 'On' and a grey button for 'Off'.
- Advanced Set:** A grey button.

On the right side, under the 'Manual Test' header, there are four orange buttons for testing different components, each with a corresponding value field:

- Glow Plug:** Volt 0.0
- Fire Valve:** Cur 0.0
- Prime Valve:** RPM 0
- Starter:** (no value field)

At the bottom right, there is a yellow 'Back' button.

---

## C. Power-On Precautions

When powering on the engine, you must first connect the aviation plug to the engine properly, and then connect the battery!

If you connect the battery and GSU first, and then insert the aviation plug into the engine, it will burn out the ECU or GSU.

When powering off the engine, you must first disconnect the battery, and then disconnect the aviation plug.

If the internal temperature of the engine is above 70 °C when powered on, the engine will enter the automatic cooling program for heat dissipation. In this case, the engine will not perform self-check upon power-on.

If the remote control has not performed throttle learning with the engine, after power-on, the engine’s starter motor may activate and enter the cooling program. Once throttle learning is completed, it will return to normal.

### (2) Throttle Learning

On the main page, click the “Start” button to enter the start page.

Click the “Pairing Settings” button — once this button turns green, throttle learning begins.

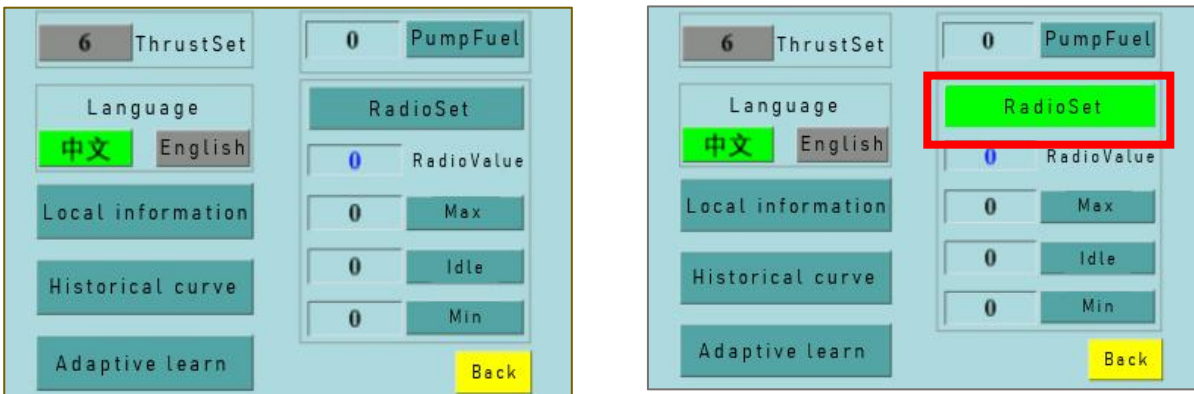

Once the “Pairing Settings” button turns green, pairing set-up begins.

A. Push the remote control throttle stick to the maximum position, set the trim to the maximum, then click the “Max” button. A dialogue box will pop up — select “Yes”. The maximum throttle setting is now complete.

-----

B. Push the remote control throttle stick to the minimum position and set the trim to minimum, then click the **“Stop”** button. A dialogue box will appear — select **“Yes”**. The stop throttle setting is now complete.

C. Click the **“Pairing Settings”** button. Once this button turns gray, the throttle learning process is fully complete.

D. **Note:** When the **“Pairing Settings”** button is green, the GSU has isolated the remote control data from the engine ECU, and the engine cannot be controlled. When the **“Pairing Settings”** button turns gray, the remote control data is connected to the engine, allowing control of the engine.

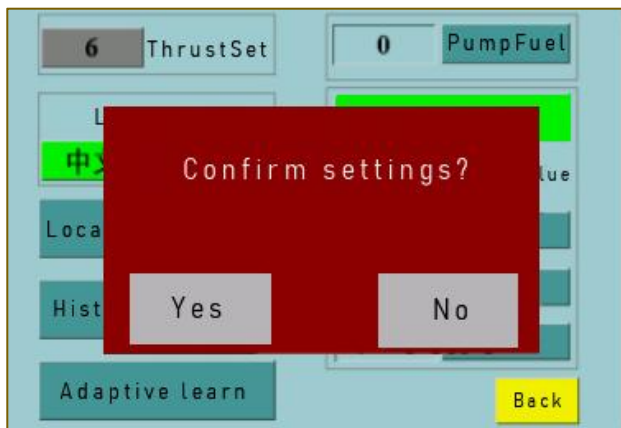

### (3)Fuel Pump Operation

A. On the main page, click the **“Setup”** button to enter the start page. Press and hold the **“PUMP FUEL”** button — the fuel pump motor will continuously accelerate until it reaches 6000 RPM. At the same time, the main fuel solenoid valve will automatically open.

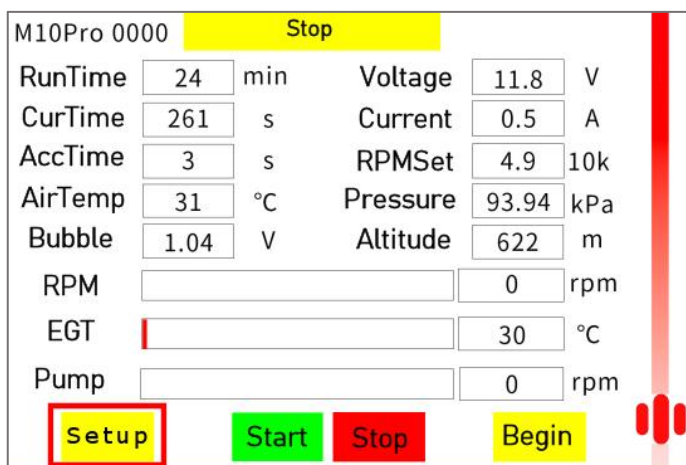

B. After fuel enters the engine injector, wait another 0.5 seconds before releasing the button. The fuel pump motor will then stop pumping.

C. Avoid running the fuel pump at high speed for long periods without fuel, as this causes dry friction. The fuel pump has already undergone break-in and performance testing before leaving the factory. Additional break-in will reduce its service life

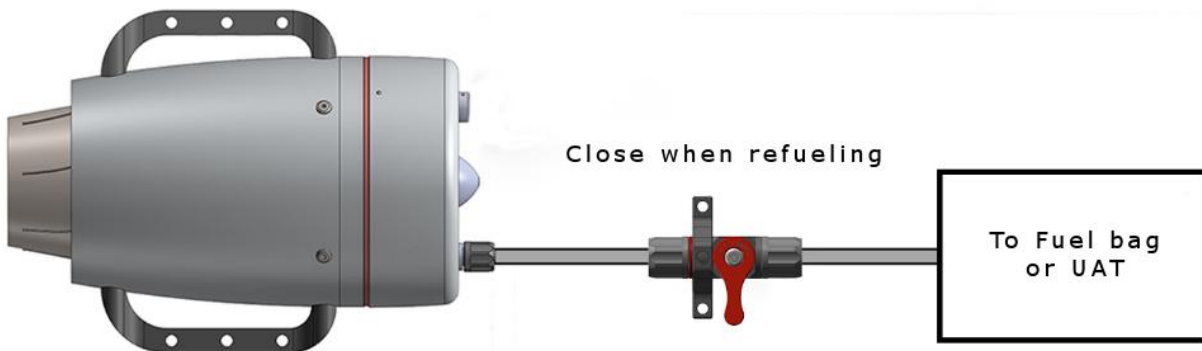
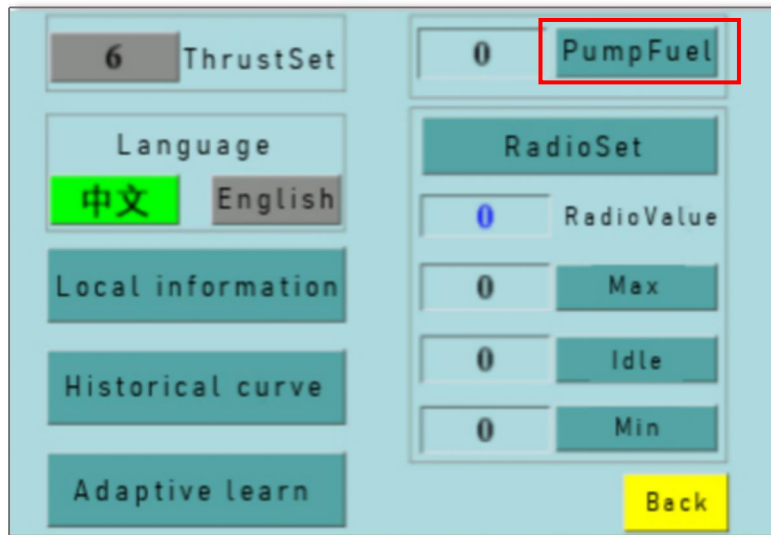

D. When refueling the tank, fill slowly. Kerosene and diesel have high viscosity, and filling too quickly will put excessive pressure on the fuel tank, which may cause the tank to burst or allow fuel to enter the engine and accumulate. This can result in large flames being emitted during start-up. A ball valve must be installed between the anti-bubble fuel tank and the engine to prevent fuel from flowing into the engine.

---

## (4) Maximum Thrust Setting

- A. Click the “Start” button on the main page to enter the start page.
- B. Click the “Thrust Setting” button to set the engine’s maximum thrust limit. The input value range is 6–10 (for example, 6, 7, 8–10). Click “OK” to save



- C. The setting takes effect after performing adaptive learning.

## (5) Engine Start

### A. Starting the Engine via GSU

The GSU (Ground Support Unit) connects to the ETU using a 4-section 3.5 mm cable. After connecting to the ETU, do not let the other end of the cable (male connector) touch the engine casing, as this could cause a short circuit and damage the ECU.

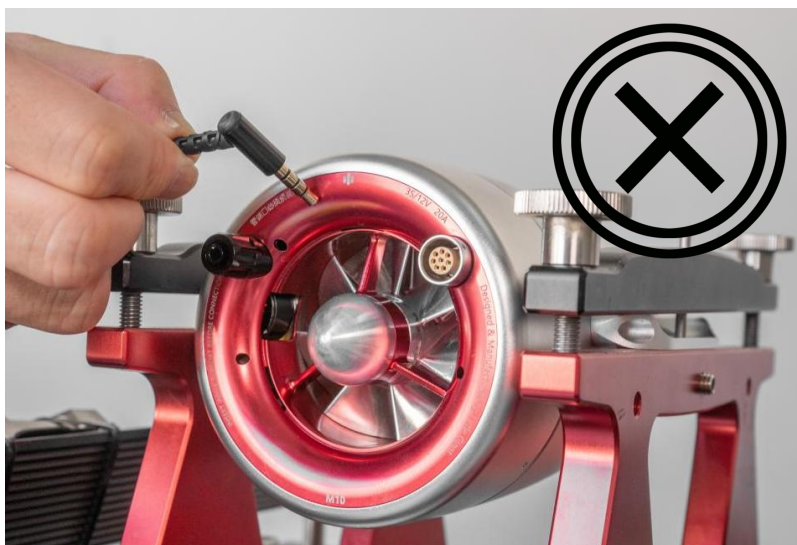

It is possible to use the GSU alone to start and control the engine without the need for a remote controller or other accessories.

On the main page, click the **“Run”** button to start the engine. Control the engine speed by sliding the 3 line logo slider up or down on the far right of the screen. Click the **“Stop”** button to stop the engine.

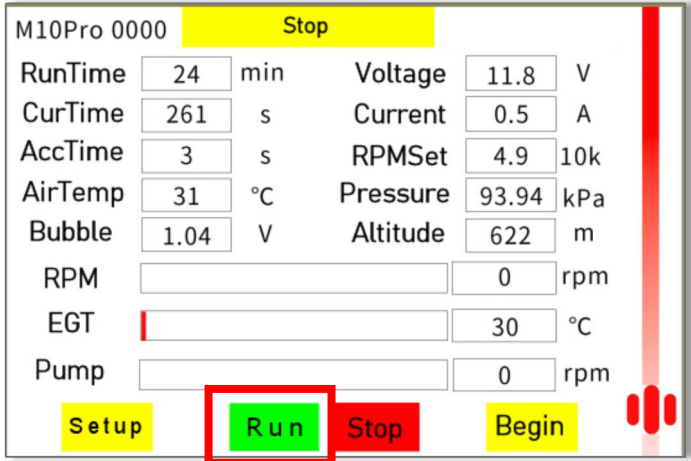

When the receiver and the GSU are connected to the engine at the same time, the engine control unit will prioritize the receiver signal as the primary source for controlling the engine.

At this time, the **“Run”** label and the **slider** on the GSU main page will turn grey, indicating that the engine can only be started and its speed adjusted using the remote controller.

When the remote controller and the GSU are connected to the engine at the same time, the **“Stop”** button on both the remote controller and the GSU main page can stop the running engine.

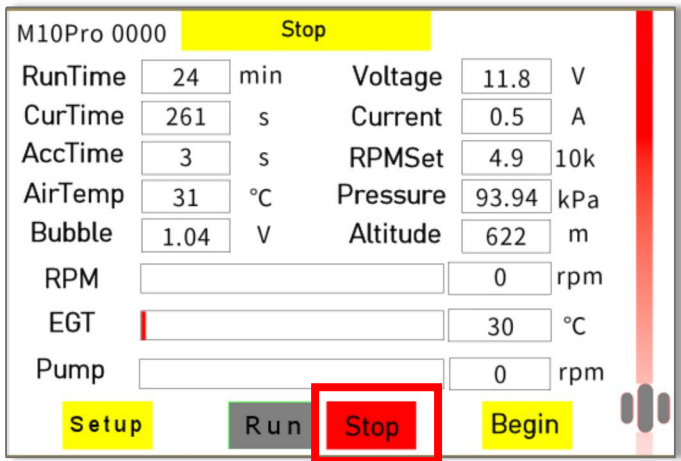

---

## B. Starting the Engine with the Remote Controller

Set the remote controller throttle stick to the minimum position and the throttle trim to the minimum position (at this time, the GSU main page will display “**Stop**”

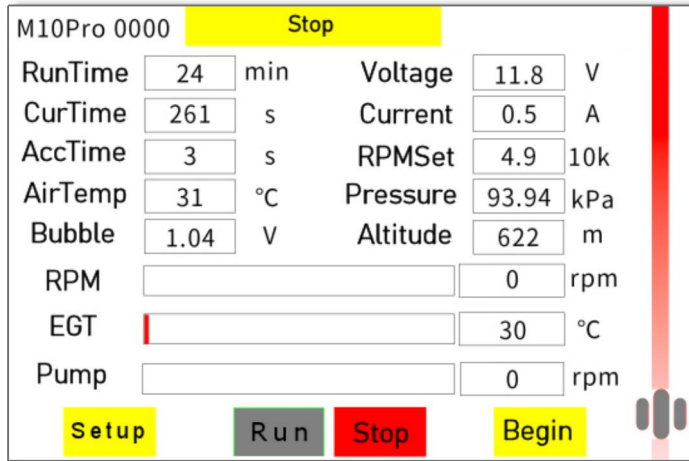

Then set the throttle trim to the maximum position, with the throttle stick in the idle position (at this time, the GSU main page will display “**Ready**”;



Push the throttle lever to the maximum position (at this time, the GSU main screen displays 'Pull down to start 3 2 1'), then pull the throttle lever down to the idle position within 3 seconds. The engine will automatically start.

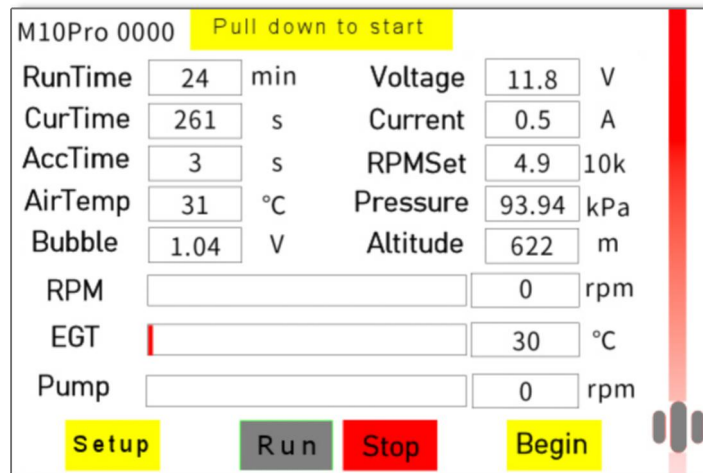

◆ **To prevent accidental start up:** ◆

a. If the throttle lever is not pulled down to the idle position within 3 seconds, the engine will not start. To restart the engine, return the throttle lever to the idle position (at this time, the GSU main screen will display “Ready”), and repeat the startup procedure (push up, then pull down the throttle lever).

b. If the throttle lever is moved after performing the “fine-tune minimum” and “fine-tune maximum” operations but not to the start up position, or if the throttle lever is moved too quickly after “fine-tune maximum,” the engine will enter manual cooling mode instead of starting. You must repeat the sequence—fine-tune minimum, fine-tune maximum, push up, and pull down—to successfully start the engine.

## (6) Adaptive Learning

Perform a semi-automatic engine adaptive learning procedure in the following scenarios: first-time engine operation, thrust setting adjustment, fuel line update, filter element replacement, significant ambient temperature changes of the engine (e.g., seasonal shifts) after the last learning process, or significant altitude changes. Additionally, conduct semi-automatic adaptive learning when the engine stalls upon throttle actuation or experiences speed hanging (engine maintains a low speed without further acceleration despite a full-throttle command) after being moved to a new environment or having its fuel line modified. The engine will perform adaptive learning automatically under all other conditions. Adaptive learning enables the engine to maintain an optimal matching state with the atmospheric and fuel line environments, effectively reducing the risk of stalling during acceleration and deceleration.

### Semi-automatic Adaptive Learning Procedure:

After starting the engine, set the remote controller throttle stick (or GSU throttle slider) to the idle position and wait for several seconds. Once the GSU screen displays Idle Learning Completed, slowly push the remote controller throttle stick (or GSU throttle slider) uniformly to the maximum position over

a 3–5 second period, then wait for several seconds. Adaptive learning is completed when the GSU screen displays Full-speed Learning Completed.

During semi-automatic learning, the engine will gradually learn the matching values for the current environment based on the factory-set pump speed. At idle and full-speed, the engine will automatically learn the corresponding values after a short waiting period.

## (7) Acceleration and Deceleration Settings

The acceleration and deceleration response times of the engine during operation are pre-set at the factory. Depending on the variations in the user's local altitude and temperature, the acceleration time from idle speed to the maximum speed of 150,000 RPM is generally about 2.7-3.8 seconds, and the deceleration time is about 3-6 seconds. These acceleration and deceleration times can meet the flight requirements of most scenarios. Adjustments to the acceleration and deceleration parameters take effect immediately without the need to shut down the engine, and can be operated directly while the engine is running.

For users pursuing extremely fast acceleration and deceleration response times, the speed can be adjusted through the settings in the Advanced Settings. The specific methods are as follows:

- a. Acceleration Time: The response time of the engine from idle speed to full speed, with an adjustable range of 2-20 (Unit: second).
- b. Deceleration Time: The response time of the engine from full speed to idle speed, with an adjustable range of 2-20 (Unit: second).
- c. If the engine stalls during sudden acceleration (or deceleration), increase the corresponding Acceleration Time/Deceleration Time value, then repeatedly conduct sudden acceleration and deceleration tests from idle speed to full speed and back to idle speed, following the principle of no stalling.
- d. The minimum adjustment increment is 0.1 unit, e.g., 3.1, 3.2, 3.3 ... 19.9, 20.0.

Advanced Set					
GlowSec	5	Phoil	2000	LowRpm	200
GlowVol	6.2	PhRpm	15000	ThOil	4500
GlowRpm	7500	AccDutvy	30	PumpDuty	125
GlowOil	4000	PhDuty	60	IdleRpm	46000
GloTime	8	PhTempe	100	AccTime	3.0
TRatio	0.3	PhMinTm	0	DecTime	4.0
AccRate	2000	ThRpmSW	17000	Save	Back

---

## (8) Stall Restart

Enter the "Settings" page and click the "Flameout Restart" switch to enable or disable this function. A green background indicates the current active setting. When the function is enabled, if the engine stalls without receiving any shutdown command during operation, it will immediately initiate flameout restart. The restart process takes approximately 15 seconds with one restart attempt. If the restart fails, the engine will enter the shutdown cooling procedure.

To improve restart speed, the fuel supply during flameout restart is significantly higher than during normal startup, which may cause excessive flame emission. However, during flight, the incoming airflow ensures this flame has no impact on the aircraft structure or safety. On the ground, intentional or unintentional activation of flameout restart may damage the aircraft. If the engine stalls on the ground after installation, immediately set the remote control trim to the minimum position and shut down the engine—avoid using the flameout restart function on the ground.

It is recommended to set the remote control trim travel to 3 levels. If the engine stalls after the aircraft takes off, the pilot can decide whether to shut down the engine based on real-time altitude and speed conditions to prevent restart from interfering with forced landing operations. This setting prevents misoperation while enabling quick control of engine start/stop.

◆ Users must assess the risks of the engine flameout restart function based on their professional knowledge before deciding whether to enable it. ◆

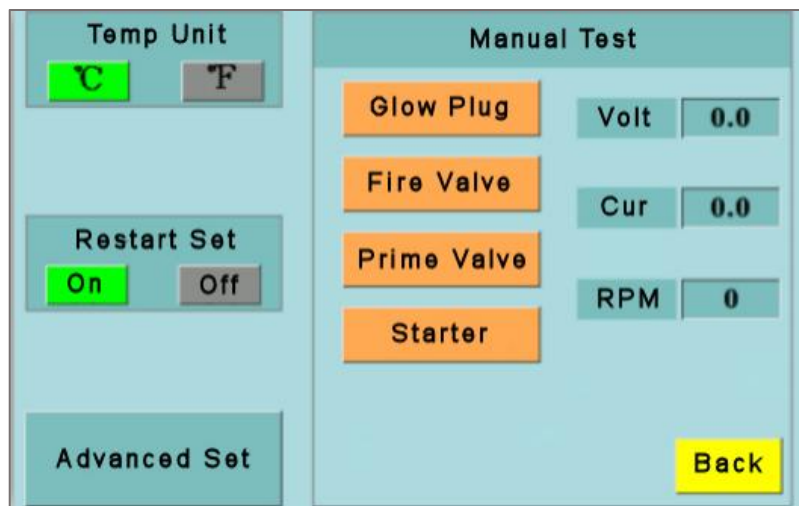

## (9) Loss of Control Protection Strategy

After the receiver loses signal, there are two possible states for the receiver (depending on the remote controller settings):

- The receiver continues to maintain the last command before signal loss;
- The signal between the receiver and the engine is lost.

When the engine is running:

In the first case, the engine will maintain the current speed and continue running;

In the second case, the engine will maintain the current speed for 3 seconds, then drop to idle and hold for 10 seconds. If the signal is still not restored, the engine will enter the shut-down procedure.

◆ If the engine regains the receiver signal within 13 seconds, it will continue to run according to the current position of the remote controller's throttle lever. ◆

## (10) Engine Shut-down

When the remote controller throttle lever is set to minimum and the throttle fine-tune is also at minimum, the engine will shut down and enter the automatic cooling phase. During cooling, the motor speed is maintained at 7,000 RPM. When the internal engine temperature drops below 70°C, the engine stops cooling.

◆ The engine must not be restarted before the cooling process is complete ◆

## (11) Manual Cooling

Manual cooling can be performed via the remote controller. Set the throttle lever and fine-tune to the minimum position, then push the throttle lever to the maximum position to start manual cooling. Pull the throttle lever back to the minimum position to stop manual cooling.

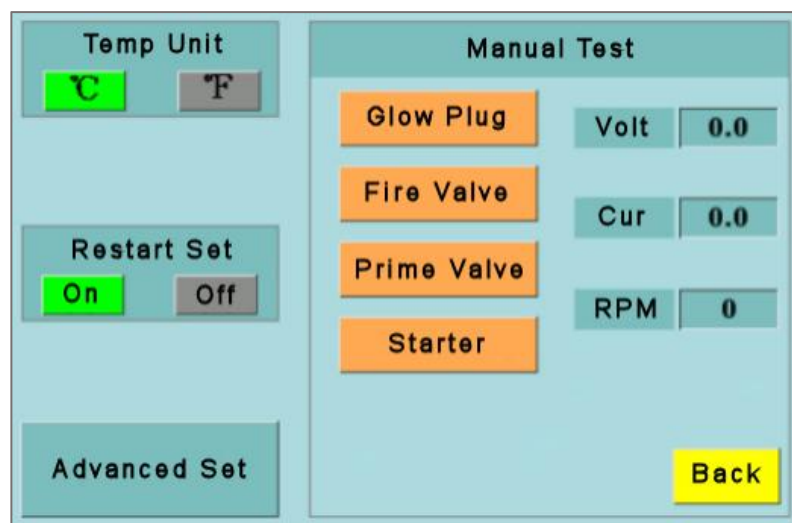

Manual cooling can also be performed through the GSU. Enter the “Settings” page and click “Start Motor” to enable manual cooling. Click “Start Motor” again to disable manual cooling.

## (12) Viewing Historical Data

You can view data such as RPM, fuel pump status, throttle signals, and fuel line bubbles for each start, stop, and flight through the GSU historical data viewing function.

On the GSU “Start” screen, click “History Curve.

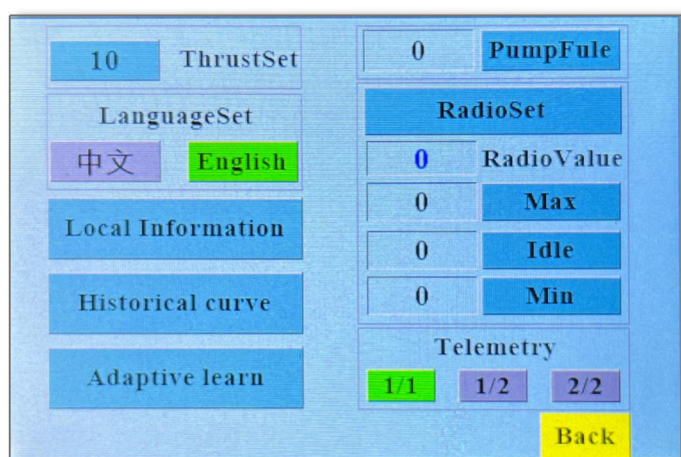

In the history curve section, first click the upper-left corner to select the data and find the flight start-stop data you want to view. Numbers followed by the letter “E” indicate that a stall occurred during that run. Historical flight start-stop data are listed in reverse chronological order (the most recent start-stop data is at the top). You can view the data as needed—for example, click on “R00002E.csv”.

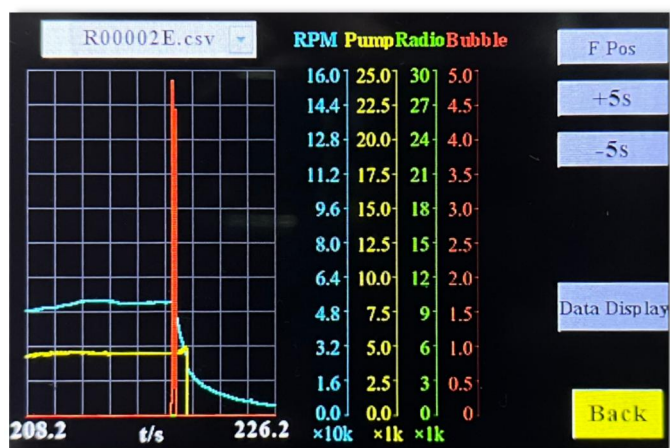
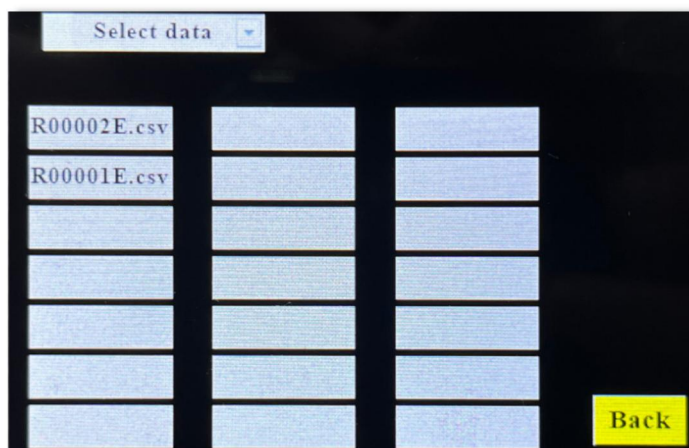

Clicking “**Data Playback**” will automatically replay the start-stop data for the selected session. Clicking “Data Playback” again will pause the playback at the current position. Different colored curves represent different parameters. The **horizontal axis** represents data values, while the **vertical axis** represents time, with each interval on the vertical axis representing 2 seconds.

As shown in the figure above, **red** represents **fuel line bubbles**. A peak in the red curve corresponds to a bubble value of **5.0**, indicating that between **218 to 220 seconds** into this flight, large air bubbles appeared, causing the engine to stall.

◆ Historical data for the current session can only be viewed after the cooling process is complete.

### (13) Advanced Settings

## M10Pro Engine · Advanced Settings User Guide

The advanced setting functions of the M10Pro engine are mainly designed to adjust the engine's status and performance during the startup phase as well as the acceleration and deceleration phases of operation, so as to adapt to the fuel line conditions of different aircraft and environmental changes.

Advanced Set					
GlowSec	5	PhRpm	15000	PumpDuty	125
GlowVol	6.2	AccDutvy	30	IdleRpm	46000
GlowRpm	7500	PhDuty	60	ACCcoef	1.00
GlowOil	4000	PhTempe	90	DECcoef	1.00
GloTime	8	PhMinTm	0	RegCoeff	1.00
TRatio	0.2	ThRpmSW	17000	UpLimit	1.30
AccRate	2000	LowRpm	200	DmLimit	0.50
Phoil	2000	ThOil	5000		
				Save	Back

During factory debugging, the M10Pro engine reserves a certain amount of redundancy for the engine startup time and the acceleration/deceleration response time during operation. For users pursuing optimal performance, fine-tuning via advanced settings is available to unlock the engine's maximum potential

Given the complexity of controlling the engine during acceleration and deceleration, along with the large number of associated parameters, we will continuously optimize the parameter settings in subsequent updates to simplify the user parameter configuration process as much as possible.

Should you have any questions about the following settings, please contact the technical support team at Xiaojuren Company. We are always ready to provide you with professional assistance.

The diagram below shows the advanced parameter settings and usage instructions for the FTL Vortex M10 Pro engine::

	Name	Explanation	Range	Typical Setting	unit	notes
Ignition Phase	GlowSec	After the start command is issued, the igniter operates for the specified number of seconds before proceeding to the next step	3-6	5	s	- If ignition is difficult or the ambient temperature is below zero, the preheating duration can be increased.
	GlowVol	The operating voltage of the igniter	5.8-6.5	6	V	-If too low ignition will fail -If too high the igniter is prone to damage
	GlowRPM	When the speed reaches this value the ignition fuel circuit opens.	6500-8000	7500	rpm	-This is the standard value and will vary with altitude. -Too Low: insufficient oxygen -Too high: Flame maybe be blown out or cause insufficient early ignition temperature rise rate. °
	GlowOil	The speed of the oil pump when the ignition fuel line is activated.	3000-5000	4000	rpm	- Adjust this value based on the fuel line resistance (e.g., filters). - If too low: Incomplete atomization, insufficient combustion energy, resulting in ignition failure or low temperature rise rate. - If too high: Excess oil accumulation in the engine, leading to backfire.
	GlowTime	Duration of ignition preheating	6-10	8	s	- If too short: the combustion chamber cannot be properly preheated - if too long: increases start-up time.
Acceleration / Preheating Phase	Temperature Rise Rate	A protection value used during the ignition and acceleration/preheating stages to determine whether the engine is burning normally.	0-0.3	0.3	%	- If too low: Cannot effectively serve as a protection mechanism. - If too high: A low actual temperature rise rate may lead to false shut-down judgements during start-up.

	Name	Explanation	Range	Typical Setting	unit	notes
	AccRate	The rate at which the spindle speed accelerates to the "Preheating Speed."	1500-2000	2000	rpm/s	<ul style="list-style-type: none"> <li>- If too low: The combustion chamber temperature becomes very high, increasing the risk of turbo seizure due to high temperature.</li> <li>- If too high: The combustion chamber temperature remains low, which may result in excessive liquid fuel injection or heavy smoke in the subsequent steps.</li> </ul>
	PHRPM	Oil pump speed before the engine reaches the "Preheating Temperature."	1700-2000	2000	rpm	<ul style="list-style-type: none"> <li>- If too low: Engine may stall.</li> <li>- If too high: May result in liquid fuel injection or excessive smoke.</li> </ul>
	PhRPM	Once this speed is reached, it becomes one of the conditions to enter the "Idle Thrust" stage.	15000	15000	rpm	<ul style="list-style-type: none"> <li>- If too low: Risk of backfire.</li> <li>- If too high: The starter motor may become overloaded.</li> </ul>
	AccDuty	The fuel supply ratio of the main oil valve during the transition from ignition to preheating stage.	20-50	30	%	<ul style="list-style-type: none"> <li>- If too low: The main oil valve may not open properly, and temperature rise will be slow.</li> <li>- If too high: The engine may stall during stage transition.</li> </ul>
	PhDuty	Fuel supply ratio of the main oil valve after the engine reaches preheating speed.	50-100	60	%	<ul style="list-style-type: none"> <li>- If too low: Slow temperature rise.</li> <li>- If too high: Liquid fuel injection or excessive smoke may occur.</li> </ul>
	PhTemp	Once this temperature is reached, it becomes the second condition to enter the "Idle Thrust" stage.	80-120	100	°C	<ul style="list-style-type: none"> <li>- If too low: May cause backfire, smoke, or insufficient energy during idle thrust.</li> <li>- If too high: Risk of turbo seizure due to high temperature, and longer start-up time.</li> <li>- At altitudes above 2000 meters: Set this value to 110–120°C.</li> </ul>

	Name	Explanation	Range	Typical Setting	unit	notes
Idle Thrust Stage	ThRPMS W	Speed at which the engine transitions to the "Running Stage" through slow thrust from the preheating speed	17000-18000	17000	rpm	<ul style="list-style-type: none"> <li>- If too low: Increased backfire risk in later stages.</li> <li>- If too high: Longer start-up time.</li> </ul>
	LowRPM	If engine spindle acceleration rate falls below this value during this stage, the start-up process is terminated.	100-200	200	rps	<ul style="list-style-type: none"> <li>- If too low: Prolonged engine start-up.</li> <li>- If too high: May cause false shut-down due to start-up failure.</li> </ul>
	ThOil	Pump speed supplying fuel to the engine during the transition into the "Running Stage."	3500-5000	4000-4500	rpm	<ul style="list-style-type: none"> <li>- If too low: Long start-up time or low spindle acceleration rate.</li> <li>- If too high: May cause engine backfire.</li> </ul>
	PumpDuty	Control parameter for the oil pump.	110-180	125	%	<ul style="list-style-type: none"> <li>- If too low: The oil pump may fail to complete the control transition.</li> <li>- If too high: May cause a sudden burst of blue flame near idle.</li> </ul>
Operation Phase	IdleRpm	The minimum stable engine speed maintained at 101.32 kPa and 15°C. Value: 45,000 rpm	45000	45000	rpm	<ul style="list-style-type: none"> <li>- The user's local idle speed will automatically adjust with altitude and temperature.</li> <li>- If too low: Acceleration slows down, exhaust temperature is high.</li> <li>- If too high: Idle thrust is large.</li> </ul>
	Acceleration Time	Response time of engine speed from idle to 150,000 RPM	2-20	3	s	Excessively fast acceleration time risks engine stalling.
	Deceleration Time	Response time of engine speed from 150,000 RPM to idle	2-20	4	s	Excessively fast deceleration time risks engine stalling.

## (14) Fault Information and Solutions

No.	Fault Information (Chinese)	Fault Information (English)	Error Cause Analysis	Solutions	Remarks
1	电机停转	MotorStop	<ol style="list-style-type: none"> <li>1. High rotor resistance or jamming</li> <li>2. Current protection</li> <li>3. Magnet alignment failure</li> <li>4. Motor program error</li> </ol>	<ol style="list-style-type: none"> <li>1. Return to factory for repair</li> <li>2. Actuate the motor independently and observe the instantaneous current and operating current</li> <li>3. Restart the motor</li> <li>4. Return to factory for program update</li> </ol>	
2	油泵停转	PumpStop	<ol style="list-style-type: none"> <li>1. High resistance or jamming of the oil pump motor</li> <li>2. Current protection</li> <li>3. Low oil pump duty cycle</li> <li>4. Program error</li> <li>5. Preheating pump speed lower than the normal value</li> </ol>	<ol style="list-style-type: none"> <li>1. Actuate the oil pump motor independently to check if it rotates; inspect for motor jamming</li> <li>2. Actuate the oil pump motor independently and observe the instantaneous current and operating current</li> <li>3. Increase the "Oil Pump Duty Cycle" by 10 units each time</li> <li>4. Return to factory for program update</li> <li>5. Adjust the "Preheating Pump Speed" to 2000-3000</li> </ol>	
3	超温	OverEGT	<ol style="list-style-type: none"> <li>1. Possible displacement of the thermocouple probe</li> <li>2. Engine air leakage</li> <li>3. Thermocouple damage</li> </ol>	<ol style="list-style-type: none"> <li>1. Return to factory for temperature coefficient calibration</li> <li>2. Inspect the fixing bolts of all parts</li> <li>3. Return to factory for repair</li> </ol>	
4	温度异常	TempFault	<ol style="list-style-type: none"> <li>1. Thermocouple damage</li> <li>2. Solder joint detachment of the thermocouple drive wire</li> <li>3. ECU hardware damage</li> </ol>	<ol style="list-style-type: none"> <li>1. Return to factory for repair</li> <li>2. Inspect the thermocouple soldering position</li> <li>3. Return to factory for repair</li> </ol>	
5	点火失败	IgniteBad	<ol style="list-style-type: none"> <li>1. Fuel not properly entering the engine or oil valve not opened</li> <li>2. Clogged atomizing nozzle or low ignition pump speed</li> <li>3. Ignition solenoid valve not working normally</li> <li>4. Glow plug not working or low ignition voltage</li> </ol>	<ol style="list-style-type: none"> <li>1. There are bubbles at the front end of the oil pipe or the ball valve is not open; if there are bubbles, pump fuel into the engine first; if the ball valve is not open, open it before pumping fuel into the engine</li> <li>2. Increase the "Ignition Pump Speed" by 300-500 each time; if ignition fails repeatedly, return to factory for repair</li> </ol>	

No.	Fault Information (Chinese)	Fault Information (English)	Error Cause Analysis	Solutions	Remarks
				3. Actuate the ignition solenoid valve independently to check if it works normally 4. Actuate the glow plug independently to check if it works normally (current between 2-3A); inspect the ignition voltage in Advanced Settings (6V)	
6	预热失败	PreHeatBad	1. Main oil valve not working normally 2. Preheating pump speed not within the normal range 3. Excessively high preheating speed leading to unreasonable air-fuel ratio	1. Actuate the main oil solenoid valve independently to check if it works normally 2. Adjust the "Preheating Pump Speed" to 2000 3. Adjust the "Preheating Speed" according to the phenomenon: excessive smoke, insufficient oil, or continuous fuel injection indicates high preheating speed—decrease by 1000 each time	
7	启动失败	StartBad	1. The motor cannot reach the preset speed	Return to factory for repair	
8	电压低	VoltageLow	1. Battery voltage lower than 11.4V, unable to enter the startup program	1. Replace the battery	
9	电压高	VoltageHigh	1. Excessively high maximum speed setting of the starter motor (factory setting)	1. Set to "45000"	
10	电机故障	MotorBad	1. Motor body failure 2. Solder joint detachment or damaged grounding of the motor drive wire 3. Program failure 4. Motor drive board damage	1. Return to factory for repair 2. Inspect the solder joints and insulated wires of the motor drive wire 3. Return to factory for drive program update 4. Check if the motor drive board lights up after power-on	

No.	Fault Information (Chinese)	Fault Information (English)	Error Cause Analysis	Solutions	Remarks
11	油泵故障	PumpBad	1. Oil pump motor damage 2. Solder joint detachment or damaged grounding of the oil pump motor drive wire 3. Program failure 4. Oil pump motor drive board damage	1. Return to factory for repair 2. Inspect the solder joints and insulated wires of the oil pump motor drive wire 3. Return to factory for drive program update 4. Check if the oil pump drive board lights up after power-on	
12	火头故障	FiredBad	1. Glow plug damage 2. Solder joint detachment of the drive wire or ground wire 3. ECU hardware damage	1. Return to factory for repair 2. Inspect the solder joints 3. Return to factory for repair	
13	主油阀故障	MainValveBad	1. Solenoid valve damage 2. Solenoid valve plug detachment 3. Short circuit to ground of the solenoid valve terminal wire	1. Return to factory for repair 2. Inspect if the solenoid valve plug is detached or the pins are loose 3. Inspect if the insulated wire is damaged	
14	点火阀故障	FireValveBad	1. Solenoid valve damage 2. Solenoid valve plug detachment 3. Short circuit to ground of the solenoid valve terminal wire	1. Return to factory for repair 2. Inspect if the solenoid valve plug is detached or the pins are loose 3. Inspect if the insulated wire is damaged	
15	检查油滤	CheckOilFilter	1. Clogged oil filter leading to high oil circuit resistance 2. Air leakage at each connection or sealing part of the oil circuit	1. Inspect and clean the filter element 2. Inspect each connection or sealing part of the oil circuit and the bubble sensor voltage	
16	预热超时	PreheatTimeout	1. Unreasonable preheating temperature setting 2. Unreasonable preheating pump speed setting 3. Unreasonable preheating timeout setting	1. Adjust parameters in Advanced Settings according to the phenomenon; 2. Adjust parameters in Advanced Settings according to the phenomenon; 3. The factory setting of preheating timeout is 15s	

No.	Fault Information (Chinese)	Fault Information (English)	Error Cause Analysis	Solutions	Remarks
17	温升率低	TempRate Low	1. Ignition phase: unreasonable ignition pump speed or ignition speed setting leading to abnormal ignition 2. Preheating phase: unreasonable preheating pump speed or preheating speed setting 3. Unreasonable temperature rise rate setting 4. Idle acceleration phase: engine body abnormality or high oil circuit resistance	Inspect the oil circuit and adjust the air-fuel ratio matching of each phase according to on-site conditions	
18	速升率低	SpeedRate Low	Idle acceleration phase: engine body abnormality or unreasonable air-fuel ratio	Adjust the acceleration pump speed (appropriately reduce) and throttle limit (appropriately reduce) according to on-site conditions	
19	启动超时	StartTimeout	Unreasonable acceleration timeout setting	The acceleration timeout setting is too small	
20	电机转速未至	RPMnotReached	-	-	
21	本次气泡***	ThisBubble***	1. Oil circuit air leakage 2. Bubble sensor failure	1. Current bubble threshold 2. Return to factory for repair 3. Long-press "Stop" to clear the prompt	
22	近期气泡***	RecentBubble***	1. Oil circuit air leakage 2. Bubble sensor failure	1. Cumulative recent bubble threshold 2. Return to factory for repair 3. Long-press "Stop" to clear the prompt	
23	火头电流低	LowCurrent	The glow plug is about to fail	Return to factory for repair	
24	运行电压低	LowRunVol	Low battery voltage	Replace the battery	

## 5. Definitions of Terms

Term Name	Definition
Total Time	The accumulated total operating time of the engine since it left the factory.
Start Count	The accumulated number of engine starts since it left the factory.
Maintenance Time	The remaining time until the next maintenance after the current one, counted down. When it shows 0 or a negative value, the engine should be returned to the factory for maintenance.
Flight Weight	Refers to the total weight of the engine body, oil pump, solenoid valve, ECU, and data connection cable.
Maximum Speed	The highest spindle speed reached during the previous engine operation.
Pump Full-Speed Value	The maximum speed reached by the oil pump motor during the previous engine operation.
Pump Idle-Speed Value	The corresponding speed of the oil pump motor when the engine was idling during the previous operation.
Post-Maintenance Time	The operating time after the last maintenance. This is reset to zero by the manufacturer at the time of maintenance.
Current Duration	The duration of the current engine run since the last start.
Response Time	The time it takes to go from the current speed to the speed set by the remote controller.
Standard Idle Speed	The idle speed under standard conditions (temperature of 15°C, atmospheric pressure of 1 atm or 101.32 kPa).
Local Idle Speed	The actual idle speed calculated based on the current local temperature and atmospheric pressure.
Bubble Voltage	When the engine enters idle state, the voltage displayed without any air bubbles is considered full-fuel voltage. If air bubbles enter the engine, this voltage will fluctuate.

## 6.Disclaimer

### No Warranty Statement

FTL innovation makes no guarantees, either explicit or implied, regarding the accuracy, completeness, or applicability of the information contained in this manual (including but not limited to implied warranties of merchantability or fitness for a particular purpose).

### Information and Usage Liability Waiver

The company assumes no responsibility for any direct, incidental, or consequential losses arising from errors in the manual, or from the provision, use, or implementation of its contents.

### Operational Liability Limitation

The company is not liable for any property damage, personal injury, or other losses caused by the user's failure to properly install, operate, or use the engine (including but not limited to improper operation). This disclaimer is based on the fact that the company cannot continuously monitor user operations.

### User Responsibility

- Users are obligated to fully read and understand the entire manual and to comprehensively grasp the product's features and functionality.
- Users must fully acknowledge and bear the inherent potential risks associated with operating the product.
- The company makes no promises or guarantees regarding the performance or functionality of the product; users should rely on their own professional knowledge and judgement when selecting and operating the product.

### Flight Safety Special Notes

- Flight Location: When using the company's turbojet engine for flight, users must select legally permitted and safety-compliant flight areas.
- Risk Assumption: Users must fully recognize the inherent risks of turbojet engine flight and assume full responsibility for any resulting consequences.
- Pre-flight Check: It is strongly recommended to conduct a ground simulation test before each flight to identify and eliminate potential faults.

### System Complexity and Responsibility Clarification

- Due to the highly complex technical nature of the turbojet engine and its host platform, the company cannot predict or cover all possible fault causes.
- Final Disclaimer: Therefore, except for problems directly caused by confirmed manufacturing defects in the product itself, the company bears no liability or legal responsibility for any direct or indirect loss, damage, or responsibility resulting from product use.

## 7. Warranty Policy

FTL Innovation (hereafter referred to as "XiaojuRen") promises to provide free warranty service under the following conditions within the product's valid warranty period, starting from the date of sale. Customers do not need to pay for replacement parts. Please contact FTL Innovation official after-sales service for product returns and repairs.

### Conditions for Free Warranty Service:

Warranty is valid for 1 year from the date of sale or 25 hours of total runtime, whichever comes first.

The product has been used under normal conditions within the specified warranty period, and the failure is not caused by human error.

There is no unauthorized disassembly, no modifications or additions not guided by the official manual, and the fault is not caused by human factors.

The machine serial number, factory label, and other markings are intact and unaltered.

### Situations Not Covered by Free Warranty Service:

Damage caused by human error and not related to product quality, such as crashes, fires, or falls.

Unauthorized modifications, disassembly, or shell opening not guided by the official manual.

Improper installation, usage, or operation that does not follow the manual.

Any actions not guided by the product manual leading to damage.

Damage caused by harsh environments, such as strong winds, rain, or sandstorms.

Damage due to operation in complex electromagnetic or interference-heavy environments, such as mining areas, transmission towers, high-voltage lines, or substations.

Damage caused by interference from other wireless devices, including transmitter, video signal transmission, or Wi-Fi signal interference.

Damage caused by flying with excess take-off weight.

### Additional Non-Warranty Conditions:

Damage caused by forced flight when parts are aged or damaged.

The engine has exceeded the warranty period.

## **Warranty Guidelines:**

### **Return Shipping:**

Customers must first pay for shipping to return the faulty product. Once FTL Innovation's after-sales technical team receives the product, they will inspect and diagnose the issue to determine responsibility. If the fault is confirmed to be due to a product quality defect, FTL Innovation will cover the domestic return shipping, inspection, parts, and labor costs, and will refund the customer's original domestic shipping costs.

### **Non-Warranty Cases:**

If the inspection determines the product does not meet the conditions for free repair, FTL Innovation will contact the customer to either return the original product (with the customer covering shipping), or proceed with paid repair after agreement.

### **Out-of-Scope or Human-Caused Damage:**

If the issue is not covered by warranty or is caused by user error, fees may be charged depending on the nature of the issue. These may include diagnostic fees, parts replacement, testing fees, and labor costs, all of which will be clearly communicated to the customer in advance.

### **Repair Process Inquiries:**

For the repair process or maintenance records, please contact FTL Innovation after-sales support.

### **Proper Packaging:**

The product must be properly packaged when sent back for repair. FTL Innovation is not liable for any damage or loss that occurs during return shipping due to poor packaging.

\*This manual will be continuously updated in line with product iterations and user feedback. The latest version can be obtained through the official website ([www.xjjet.com](http://www.xjjet.com)) or the official WeChat group.

***Precision at 1ppm.***